

**1.6W AUDIO AMPLIFIER**

- OPERATING VOLTAGE 1.8 TO 15 V
- LOW QUIESCENT CURRENT
- HIGH POWER CAPABILITY
- LOW CROSSOVER DISTORTION
- SOFT CLIPPING

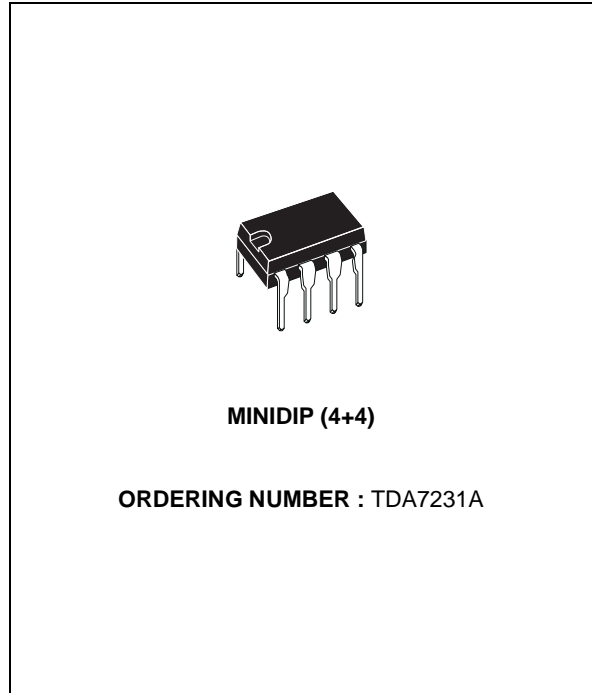

**DESCRIPTION**

The TDA7231A is a monolithic integrated circuit in 4 + 4 lead minidip package. It is intended for use as class AB power amplifier with wide range of supply voltage in portable radios, cassette re-records and players, etc.

**PIN CONNECTION**

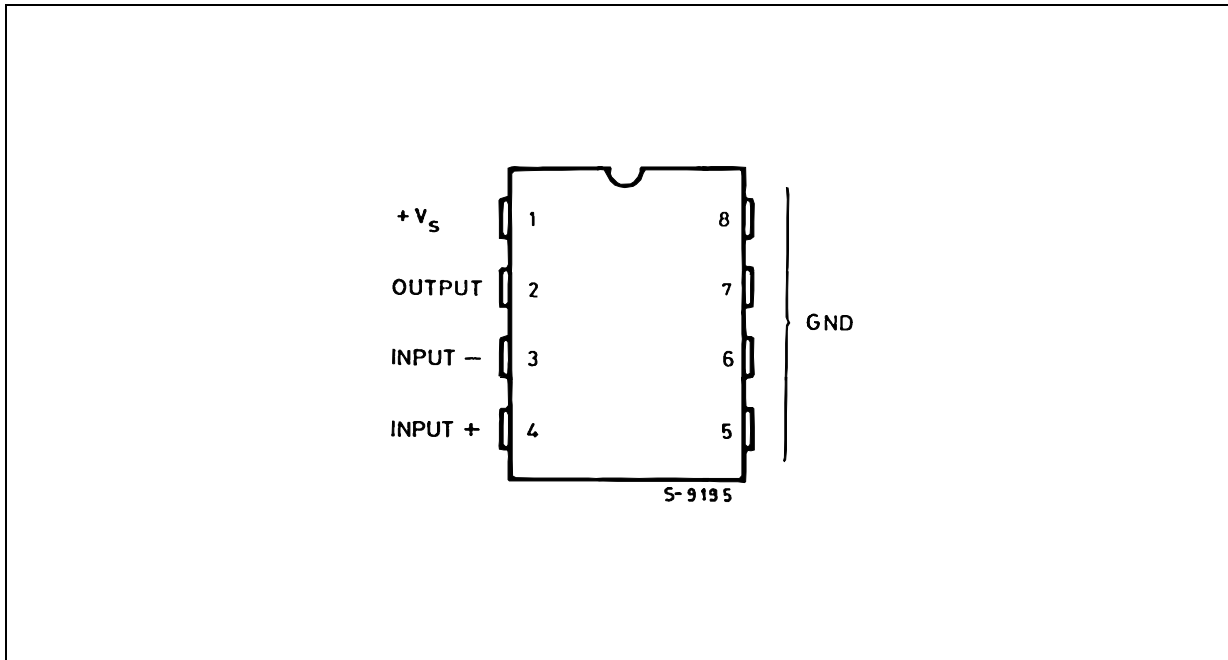

**ABSOLUTE MAXIMUM RATINGS**

Symbol	Parameter	Value	Unit
$V_s$	Supply Voltage	16	V
$P_{tot}$	Total Power Dissipation at $T_{amb} = 50\text{ }^\circ\text{C}$ at $T_{case} = 70\text{ }^\circ\text{C}$	1.25 4	W W
$I_o$	Output Peak Current	1	A
$T_{stg}, T_j$	Storage and Junction Temperature	- 40 to 150	$^\circ\text{C}$

**THERMAL DATA**

Symbol	Parameter	Value	Unit
$R_{th\ j-amb}$	Thermal Resistance Junction-ambient	Max. 80	$^\circ\text{C/W}$
$R_{th\ j-pins}$	Thermal Resistance Junction-pins	Max. 15	$^\circ\text{C/W}$

**ELECTRICAL CHARACTERISTICS** ( $V_s = 6\text{ V}$ ,  $T_{amb} = 25\text{ }^\circ\text{C}$ , unless otherwise specified)

Symbol	Parameter	Test Conditions	Min.	Typ.	Max.	Unit
$V_s$	Supply Voltage		1.8		15	V
$V_o$	Quiescent Out Voltage	$V_s = 6\text{ V}$ $V_s = 3\text{ V}$		2.7 1.2		V V
$I_d$	Quiescent Drain Current			3.6	9	mA
$I_b$	Input Bias Current			100		nA
$P_o$	Output Power	$d = 10\%$ $f = 1\text{ kHz}$ $V_s = 12\text{ V}$ $R_L = 8\Omega$ $V_s = 9\text{ V}$ $R_L = 4\Omega$ $V_s = 6\text{ V}$ $R_L = 8\Omega$ $V_s = 6\text{ V}$ $R_L = 4\Omega$ $V_s = 3\text{ V}$ $R_L = 4\Omega$ $V_s = 3\text{ V}$ $R_L = 8\Omega$		1.8 1.6 0.4 0.7 110 70		W W W W mW mW
$d$	Distortion	$P_o = 0.2\text{ W}$ $f = 1\text{ kHz}$ $R_L = 8\Omega$		0.3		%
$G_v$	Closed Loop Voltage Gain			38		dB
$R_{in}$	Input Resistance	$f = 1\text{ kHz}$	100			k $\Omega$
$e_N$	Total Input Noise	$R_s = 10\text{ k}\Omega$ $B = \text{Curve A}$ $B = 22\text{ Hz to } 22\text{ kHz}$		2 3		$\mu\text{V}$ $\mu\text{V}$
SVR	Supply Voltage Rejection	$f = 100\text{ Hz}$ , $R_g = 10\text{ k}\Omega$	24	33		dB

**Figure 1 : Test and Application Circuit**

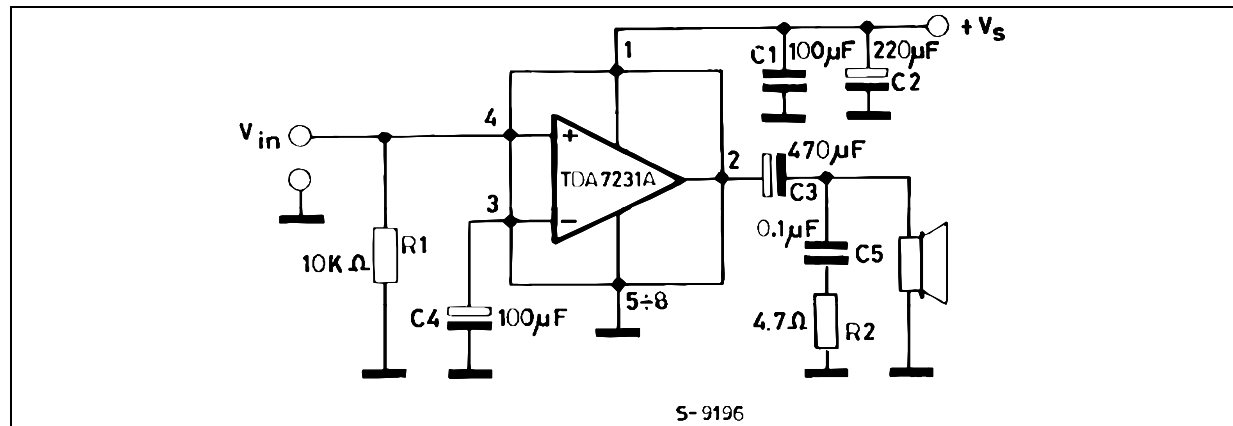

5- 9196

Figure 2 : P.C. Board and Components Layout of the figure 1 (1:1 scale)

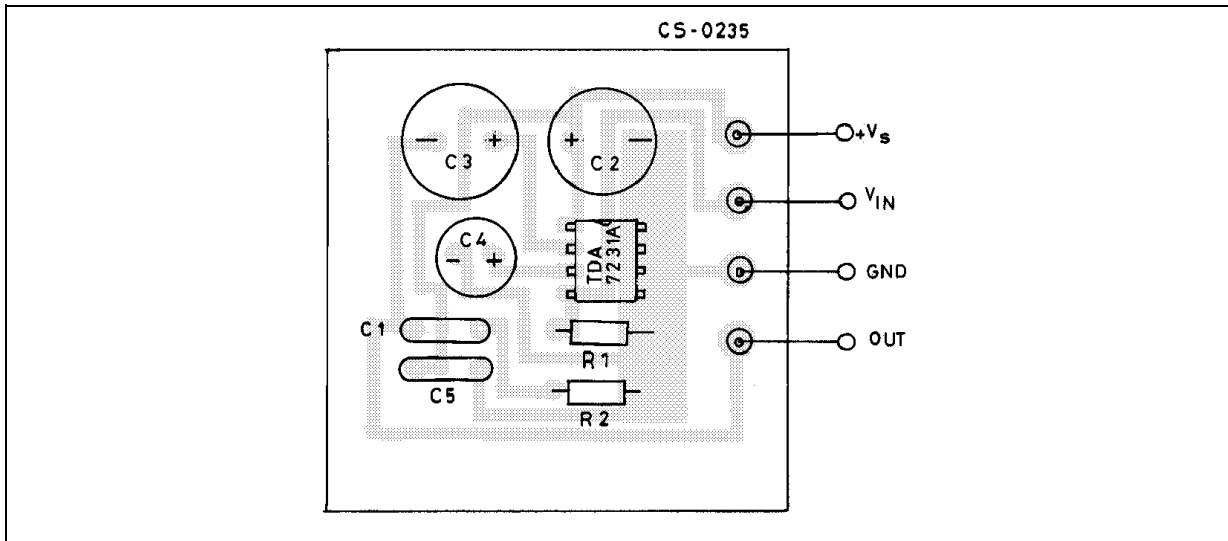

Figure 3 : Output Power versus Supply Voltage

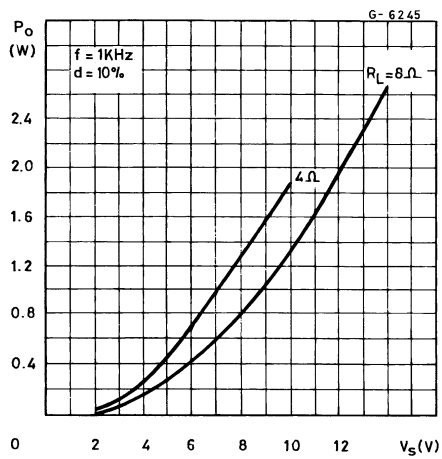

Figure 5 : Quiescent Output Voltage versus Supply Voltage

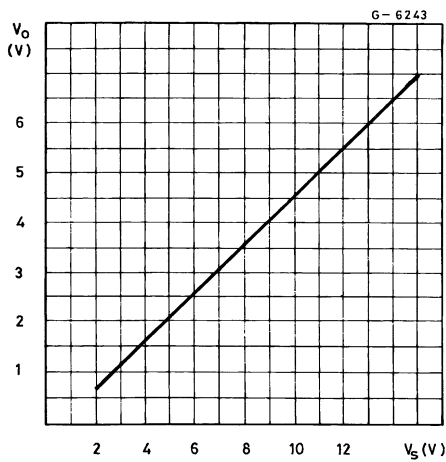

Figure 4 : Quiescent Current versus Supply Voltage

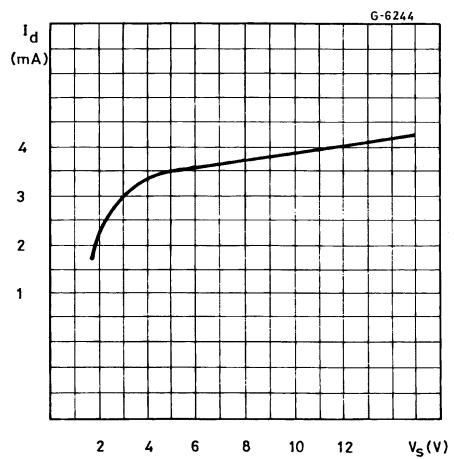
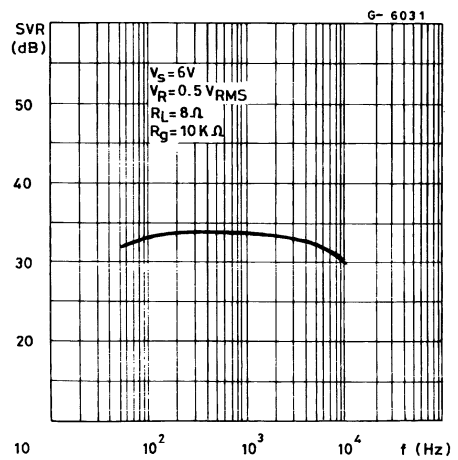
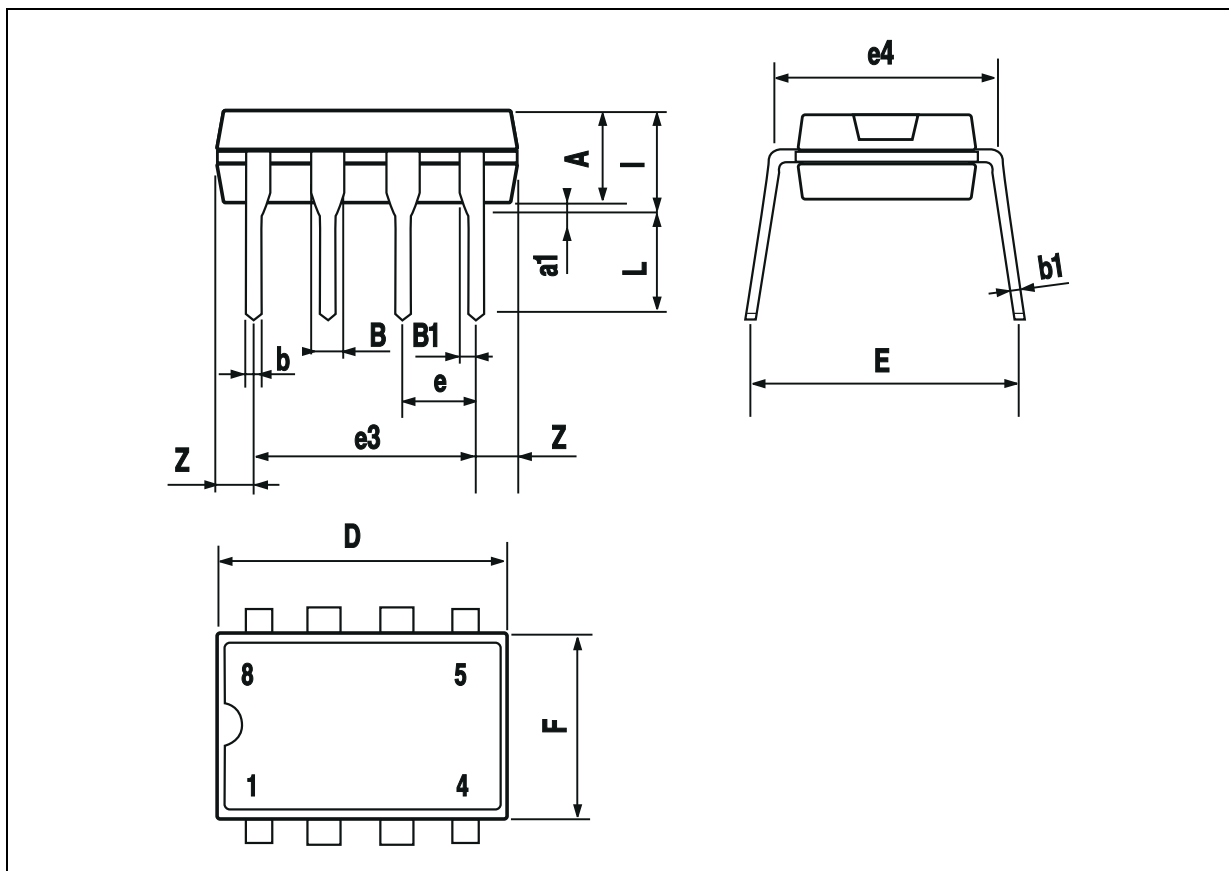

Figure 6 : Supply Voltage Rejection versus Frequency



MINIDIP PACKAGE MECHANICAL DATA

DIM.	mm			inch		
	MIN.	TYP.	MAX.	MIN.	TYP.	MAX.
A		3.3			0.130	
a1	0.7			0.028		
B	1.39		1.65	0.055		0.065
B1	0.91		1.04	0.036		0.041
b		0.5			0.020	
b1	0.38		0.5	0.015		0.020
D			9.8			0.386
E		8.8			0.346	
e		2.54			0.100	
e3		7.62			0.300	
e4		7.62			0.300	
F			7.1			0.280
I			4.8			0.189
L		3.3			0.130	
Z	0.44		1.6	0.017		0.063



Information furnished is believed to be accurate and reliable. However, SGS-THOMSON Microelectronics assumes no responsibility for the consequences of use of such information nor for any infringement of patents or other rights of third parties which may result from its use. No license is granted by implication or otherwise under any patent or patent rights of SGS-THOMSON Microelectronics. Specifications mentioned in this publication are subject to change without notice. This publication supersedes and replaces all information previously supplied. SGS-THOMSON Microelectronics products are not authorized for use as critical components in life support devices or systems without express written approval of SGS-THOMSON Microelectronics.

© 1995 SGS-THOMSON Microelectronics - All Rights Reserved

SGS-THOMSON Microelectronics GROUP OF COMPANIES

Australia - Brazil - France - Germany - Hong Kong - Italy - Japan - Korea - Malaysia - Malta - Morocco - The Netherlands - Singapore - Spain - Sweden - Switzerland - Taiwan - Thailand - United Kingdom - U.S.A.